

# FAIRCHILD

## REVERSING RELAY

Model 25

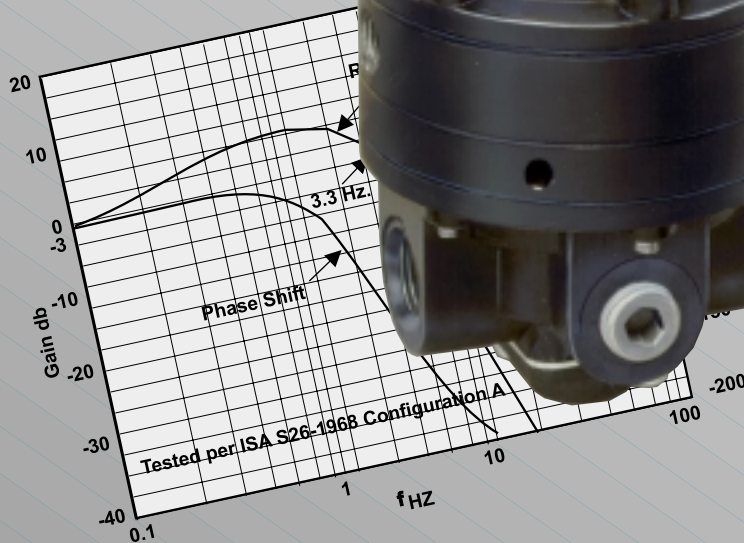
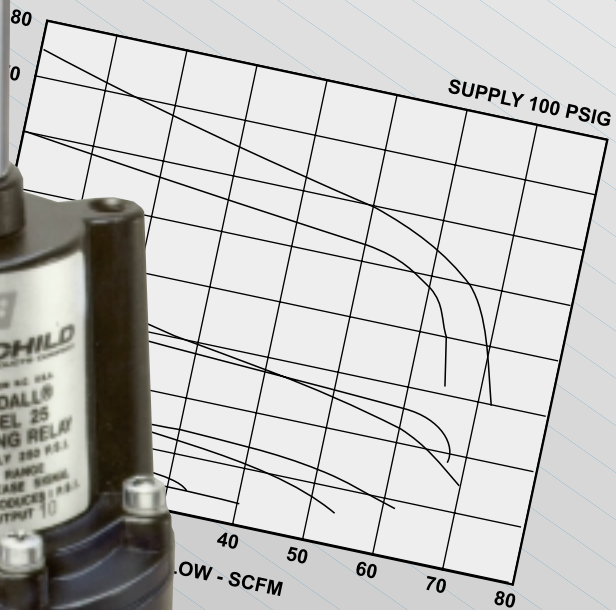
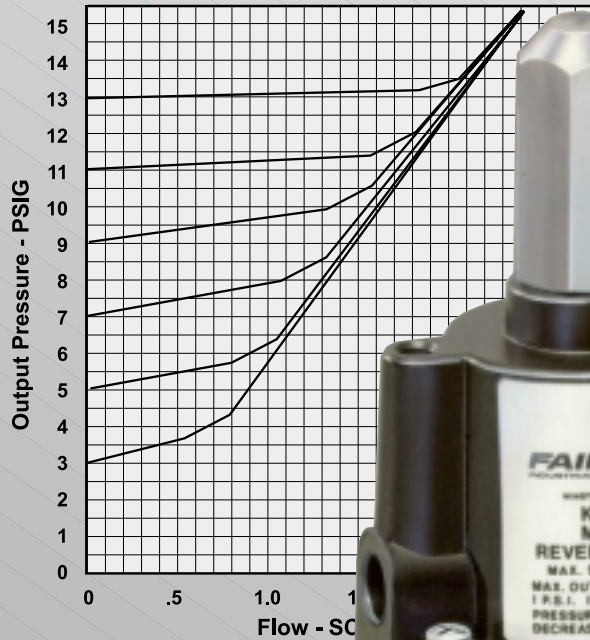

**FAIRCHILD**  
INDUSTRIAL PRODUCTS COMPANY

## GENERAL INFORMATION

### MODEL 25 REVERSING RELAY

#### APPLICATIONS

The Model 25 Reversing Relay provides an output which will decrease in direct proportion to an increase in input pressure.

#### FEATURES

##### Performance

- A Balanced Supply Valve minimizes the effects of supply pressure variation.
- Aspirator Tube minimizes downstream pressure droop under flowing conditions.

##### Functional

- Flow of up to 40 SCFM with 100 psig Supply allows use in applications requiring high flow capacity.

##### Physical

- A Separate Control Chamber isolates the diaphragm from the main flow, eliminating hunting and buzzing.
- Mounting Bracket available.

#### NOTE:

The information for this catalog sheet is being upgraded to electronic format and will be available soon. Please go to the Information Request section of this web site to order the latest printed revision.

# — ORDERING INFORMATION —

<b>Catalog Number</b>	<b>2 5</b>	<input type="checkbox"/>	<input type="checkbox"/>	<input type="checkbox"/>
<b>Pressure Range</b>				
<b>psig</b>	<b>[BAR]</b>	<b>(kPa)</b>		
0-10	[0-0.7]	(0-70)	<b>(42)</b>	
0.5-30	[0.03-2]	(3-200)	<b>(43)</b>	
1-60	[0.1-4]	(10-400)	<b>(44)</b>	
2-150	[0.15-10]	(15-1000)	<b>(46)</b>	
<b>Pipe Size</b>				
1/4" NPT			<b>(2)</b>	
3/8" NPT			<b>(3)</b>	
1/2" NPT			<b>(4)</b>	
<b>Options</b>				
Tapped Exhaust				<b>(E)</b>
BSPT (Tapered)				<b>(U)</b>
BSPP (Parallel) <sup>1</sup>				<b>(H)</b>

<sup>1</sup> BSPP Threads in Inlet & Outlet Ports Only. Others BSPT.



FM NO. 25571

[www.fairchildproducts.com](http://www.fairchildproducts.com)